

	Robot model	Controller	Controlled axes	Max. load capacity at wrist [kg]	Repeatability [mm]	Mechanical weight [kg]	Reach [mm]	Motion range [°]						Maximum speed [°/s]						J4 Moment [Nm]/ Inertia [kgm ²]	J5 Moment [Nm]/ Inertia [kgm ²]	J6 Moment [Nm]/ Inertia [kgm ²]	IP Rating
								J1	J2	J3	J4	J5	J6	J1	J2	J3	J4	J5	J6				
R-1000iA	80F	R-30iA	6	80	± 0.2	620	2230	360	245	360	720	250	720	170	140	160	230	230	350	380/30	380/30	200/20	Body IP54 std. (IP67 optional) wrist & J3 arm IP67

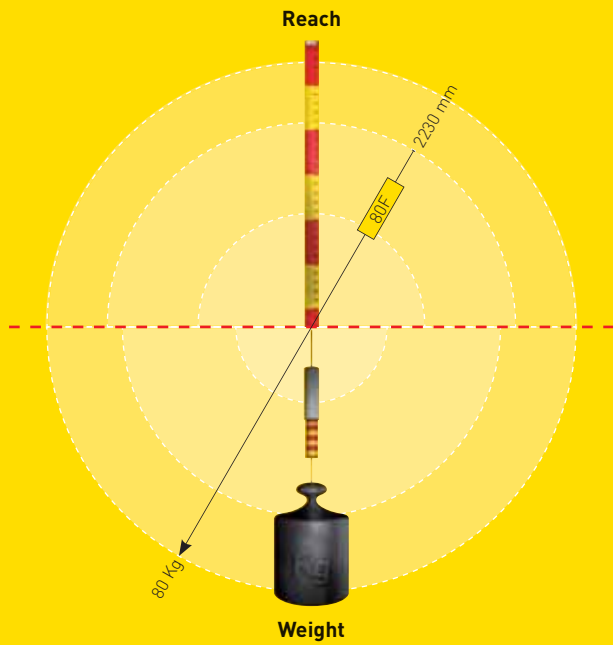

THE FANUC ROBOT R-1000iA/80F IS A NEW TOP PERFORMANCE ROBOT WITH 80KG PAYLOAD AND 2.23M REACH. THE INNOVATIVE ROBOT IS DESIGNED TO MAXIMIZE THE PRODUCTIVITY OF SPOT WELDING IN THE AUTOMOTIVE AND AUTOMOTIVE COMPONENTS INDUSTRIES.

FEATURES AND BENEFITS

R-1000iA/80F the ideal robot for compact work cells and dense production lines. Quick and robust robot for applications such as:

- Spot welding
- Material handling

FAST AND SLIM ROBOT ARM INCREASES PRODUCTION OUTPUT

- The small footprint, slim body and slim wrist of R-1000iA/80F are ideal for innovative high density spot welding cells. 3 R-1000iA/80F robots easily fit into the space required by 2 conventional spot welding robots for 50% more production output.
- The fast axes speed of R-1000iA/80F achieve more than 10% faster cycle times in typical spot welding motion than conventional robots.

MAJOR SAVINGS IN FLOORSPACE, ENERGY CONSUMPTION AND COST

- With ca. 50% less weight than conventional robots R-1000iA/80F dramatically reduces energy consumption
- With its footprint and floor space requirement ca. 50% smaller than for conventional robots R-1000iA/80F greatly reduces building costs.
- R-1000iB/80F can be ceiling mounted freeing even more space.

FASTEST AND STRONGEST ROBOT IN ITS CLASS

- In its robot class R-1000iA/80F leads the competition with the longest reach and competitive high payload capacity and top axes speeds.
- Best cycle times for short pitch spot welding achieve top productivity
- Heavy payload capacity and long reach are ideal for material handling operations.

PROVEN TOP RELIABILITY DESIGN

- Fully sealed water and dust tight (IP67) wrist and J3 arm ensure top performance and top reliability in wet and dusty environments
- Top reliability design common for R-1000iA, R-2000iB, M-900iA and M-2000iA is proven 85000 robots installed worldwide in automotive body shops, foundries and other harsh applications
- Low maintenance costs thanks to minimized downtime and minimum maintenance requirements.

J4 ROTATION AT WRIST – SLIM J3 ARM FOR EQUIPMENT MOUNTING

- With hollow drive shafts for the wrist motor the J3 arm is very slim for easy access into narrow spaces
- The J4 reducer at the end of J4 keeps the whole J3 arm stationary. Axis 4 rotates at end of arm
 - reduced wear on gripper service
 - reliable long-life design
 - simple and reliable cable dress out package
- Equipment weighing up to 15 kg can be mounted at J3 arm

STANDARD AIR AND ELECTRIC CONNECTIONS PROVIDED TO AXIS J3

- Integrated air and electrical services from J1 to J3
- Short Connections to Equipment mounted at J3 axis
- Increased wiring reliability
- Proven Reliability (factory built)

FLIP OVER CAPABILITY

- Reduced cycle time
- Enables more flexible cell designs
- Allows several robots to work together in close proximity.
- Full working envelope when robot is mounted in inverted position.

OPTION: SPOT WELDING SOLUTION ARM

The optional Solution Arm dressout packages include welding hoses, cooling water hoses and signal cables to support the spot welding process.

- Speeds up robot installation
- Maximizes uptime
- Eliminates misconnections due to human error

OPTION: ADJUSTABLE HARDSTOPS FOR MAIN AXES

Adjustable hardstops for the restriction of the axes range of J1, J2, J3 can be installed.

- Safety distances to human operator in compact robot cells can be maintained
- Robot cells size can be reduced and building cost reduced.



R-1000iA

Top view

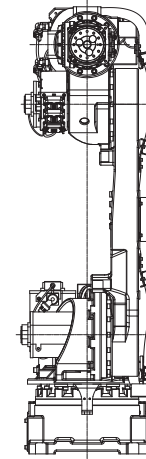
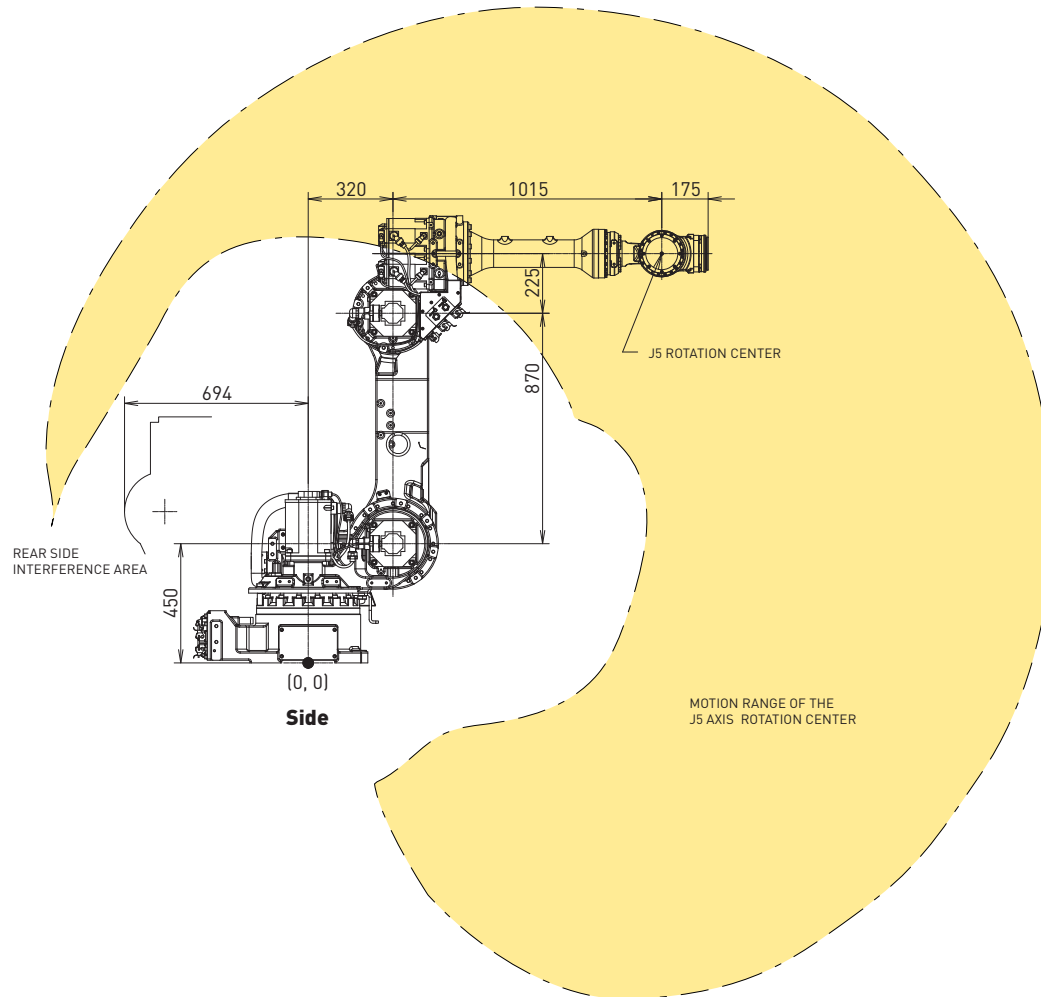
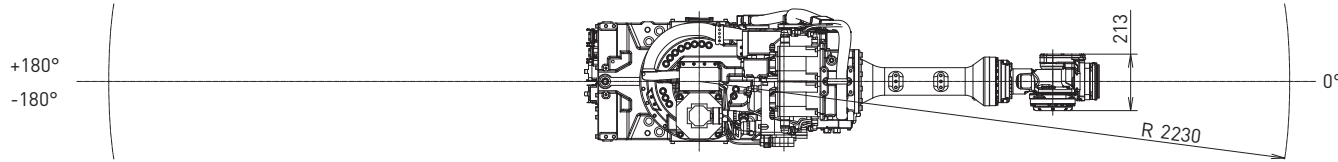

Front

